

鏈條 DIN 8187		TC-CG			TC-BC			庫存	
ISO NO.	ANSI NO.	品號	Code	A	W	品號	Code		品號
05B	-	TC-CG0S	BL010770	24	2.5	TC-BC-10X	BL010610	TC-BC10XCG0S	
06B	-	TC-CG1S	BL010771		5	TC-BC-20X	BL010612	TC-BC10XCG1S	
08B	40	TC-CG2S	BL010772		7	TC-BC-10X	BL010610	TC-BC10XCG2S	
10B	50	TC-CG3S	BL010773		9	TC-BC-20X	BL010612	TC-BC20XCG2S	
12B	60	TC-CG4S	BL010774		11	TC-BC-30X	BL010614	TC-BC20XCG3S	
16B	-	TC-CG5S	BL010775		16	TC-BC-20X	BL010612	TC-BC30XCG3S	
20B	100	TC-CG6S	BL010776	29	18	TC-BC-30X	BL010614	TC-BC20XCG4S	
05B	-	TC-CG0D	BL010780		24	2.5	TC-BC-10X	BL010610	TC-BC30XCG4S
06B	-	TC-CG1D	BL010781		5	TC-BC-20X	BL010612	TC-BC30XCG5S	
08B	40	TC-CG2D	BL010782	7	TC-BC-30X	BL010614	TC-BC40XCG5S		
10B	50	TC-CG3D	BL010783	9	TC-BC-40X	BL010616	TC-BC40XCG6S		
12B	60	TC-CG4D	BL010784	34	11	TC-BC-30X	BL010614	TC-BC30XCG6S	
16B	-	TC-CG5D	BL010785	52	16	TC-BC-40X	BL010616	TC-BC40XCG6S	
								TC-BC10XCG0D	
								TC-BC10XCG1D	
								TC-BC20XCG1D	
								TC-BC20XCG2D	
								TC-BC20XCG3D	
								TC-BC30XCG3D	
								TC-BC30XCG4D	
								TC-BC30XCG5D	
								TC-BC40XCG5D	

Sp. 特長

- 可使用在自動鏈條張力器，或衝擊吸收功能的機構
- 此產品可使鏈條的驅動正常，保持震動吸收，延長機器壽命
- 裝置簡單容易的預壓系統內藏

Ps. 備註

- 本體TC-BC和鏈條導板TC-CG，材質請參閱本單元

Ex. 使用例

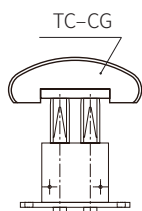

Te. 技術資料

- 使用溫度：max.80℃
- 1N = 0.101972 Kg

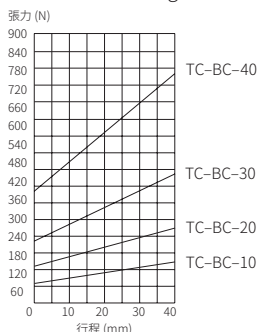

訂貨： 品號 交期： 1 天

TC-BC10XCG0S

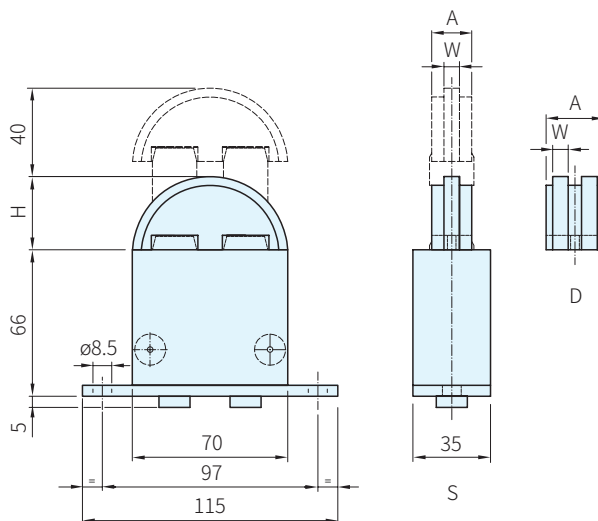

鏈條 DIN 8187		TC-CV					TC-BC			庫存	
ISO NO.	ANSI NO.	品號	Code	A	H	W	品號	Code	品號		
06B	-	TC-CV1S	BL010641	18	33	5	TC-BC-10X	BL010610	TC-BC10XCV1S	•	
08B	40	TC-CV2S	BL010642			7	TC-BC-10X	BL010610	TC-BC10XCV2S	•	
10B	50	TC-CV3S	BL010643			9	TC-BC-20X	BL010612	TC-BC20XCV2S	•	
12B	60	TC-CV4S	BL010644			11	TC-BC-20X	BL010612	TC-BC20XCV3S	•	
06B	-	TC-CV1D	BL010651			5	TC-BC-30X	BL010614	TC-BC30XCV3S	•	
08B	40	TC-CV2D	BL010652			7	TC-BC-30X	BL010614	TC-BC30XCV4S	•	
10B	50	TC-CV3D	BL010653		9	TC-BC-10X	BL010610	TC-BC10XCV1D	•		
12B	60	TC-CV4D	BL010654		11	TC-BC-20X	BL010612	TC-BC20XCV1D	•		
					21	7	TC-BC-20X	BL010612	TC-BC20XCV2D	•	
					25	9	TC-BC-20X	BL010612	TC-BC20XCV3D	•	
					30	33	11	TC-BC-30X	BL010614	TC-BC30XCV3D	•
									TC-BC30XCV4D	•	

Sp. 特長

- 可使用在自動鏈條張力器，或衝擊吸收功能的機構
- 此產品可使鏈條的驅動正常，保持震動吸收，延長機器壽命
- 裝置簡單容易的預壓系統內藏

Ps. 備註

- 本體TC-BC和鏈條導板TC-CV，材質請參閱本單元

Ex. 使用例

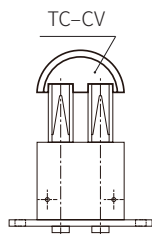

Te. 技術資料

- 使用溫度：max.80°C
- 1N = 0.101972 Kgf

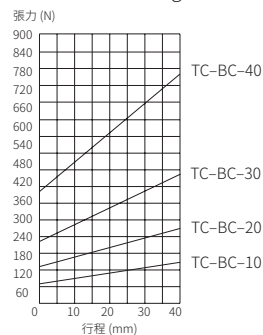

訂貨： 交期：

TC-BC10XCV1S

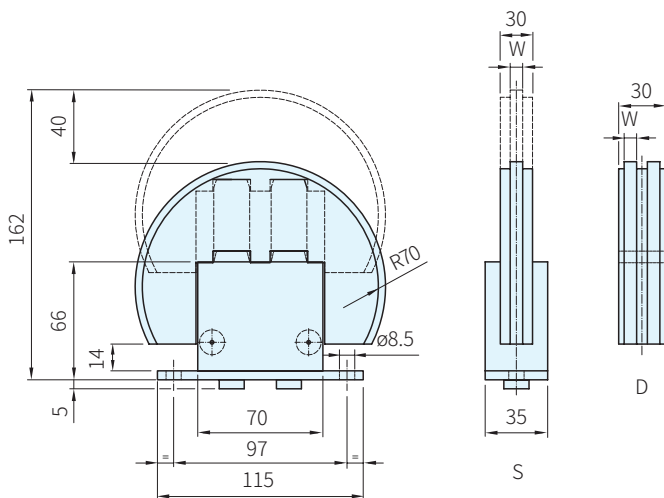

鏈條 DIN 8187		TC-CR			TC-BC			庫存
ISO NO.	ANSI NO.	品號	Code	W	品號	Code	品號	
06B	-	TC-CR1S	BL010711	5	TC-BC-10X	BL010610	TC-BC10XCR1S	•
08B	40	TC-CR2S	BL010712	7	TC-BC-20X	BL010612	TC-BC20XCR1S	•
					TC-BC-10X	BL010610	TC-BC10XCR2S	•
10B	50	TC-CR3S	BL010713	9	TC-BC-20X	BL010612	TC-BC20XCR2S	•
					TC-BC-30X	BL010614	TC-BC30XCR3S	•
12B	60	TC-CR4S	BL010714	11	TC-BC-20X	BL010612	TC-BC20XCR4S	•
					TC-BC-30X	BL010614	TC-BC30XCR4S	•
16B	-	TC-CR5S	BL010715	16	TC-BC-40X	BL010616	TC-BC40XCR5S	•
06B	-	TC-CR1D	BL010721	5	TC-BC-10X	BL010610	TC-BC10XCR1D	•
08B	40	TC-CR2D	BL010722	7	TC-BC-20X	BL010612	TC-BC20XCR1D	•
							TC-BC20XCR2D	•
10B	50	TC-CR3D	BL010723	9	TC-BC-30X	BL010614	TC-BC20XCR3D	•
							TC-BC30XCR3D	•
12B	60	TC-CR4D	BL010724	11	TC-BC-30X	BL010614	TC-BC30XCR4D	•

Sp. 特長

- 可使用在自動鏈條張力器，或衝擊吸收功能的機構
- 此產品可使鏈條的驅動正常，保持震動吸收，延長機器壽命
- 裝置簡單容易的預壓系統內藏

Ex. 使用例

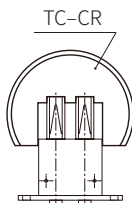

Te. 技術資料

- 使用溫度：max.80°C
- 1N = 0.101972 Kgf

訂貨： 交期：

TC-BC10XCR1S

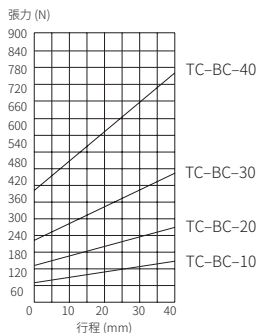

Ps. 備註

- 本體TC-BC和鏈條導板TC-CR，材質請參閱本單元